

DUR-40Ex

Intrinsically Safe

SMOKE DETECTOR

Installation and Maintenance Manual

IK-E317-001GB

IB Issue



KDB

The Universal Optical Smoke Detector DUR-40Ex covered by the present manual, complies with the requirements of the following European Union Directives:

CPD	89/106/EWG	on construction materials;
EMC	2004/108/WE	on electromagnetic compatibility;
ATEX	94/9/WE	on equipment and protective systems intended for use in potentially explosive atmospheres.

The DUR-40Ex Smoke Detector has been approved with the EC-Certificate of Conformity No. 1438/CPD/0033 issued by the Fire Protection Science and Research Centre (CNBOP) Józefów, Poland, a EU notified authority No. 1438, confirming its compliance with the requirements of PN-EN 54-7:2004 standard.

The Central Mining Institute, Katowice, Poland, a EU notified authority No. 1453, has issued the following certificates concerning the DUR-40Ex Smoke Detector:

- WE type Inspection Certificate No. KDB 05ATEX190X + Supplement No. 1
- Quality Assurance Acknowledgement No. GIG 04 ATEXQ 021
- WE Conformity Declaration No. 3/E317/2010.

The Certificates may be downloaded from www.polon-alfa.pl web site.

 1438; 1453
Polon-Alfa Limited Partnership 155, Glinki Street, PL 85-861 Bydgoszcz, POLAND 06 1438/CPD/0033
EN 54-7 DUR-40Ex Optical Smoke Detector (scattered light principal based, conventional, universal, detachable) Application – fire safety
Technical data - IK- E317-002GB manual

Read the manual carefully before assembling and operation of the base and the base attachment. Any nonconformity with the instructions contained in the manual may be harmful or may cause violation of the law in force. POLON-ALFA bears no responsibility for any damage resulting from usage inconsistent with the manual.

The waste product shall be passed to a waste electric and electronic equipment collection point.	
--	---

NOTE: The manufacturer reserves the right to change specifications of products at any time without prior notice.

1 PURPOSE

The DUR-40Ex Universal Smoke Detector is designed for detection of smoke that accompanies the majority of fires. It enables fire detection at its initial stage when material starts to smoulder what happens a long time prior to the appearance of open flame and a noticeable temperature rise. It detects every test fire that is typical for optical detectors and additionally TF1 test fire typical for ionisation smoke detectors. The DUR-40 smoke detectors are connected to fire detecting lines through **intrinsically safe barrier or separator of the following parameters: $U_o \leq 25\text{ V}$, $I_o \leq 99\text{ mA}$.**

The detectors are installed in rooms and zones qualified as 1st and 2nd explosive hazard category resulting from potential explosion danger of explosive gases or inflammable liquid vapours that are ranked at IIA, IIB and IIC explosiveness subgroups and T1 up to T6 temperature classes. The detector is characterised by an increased resistance to wind influence and atmospheric pressure changes. It provides a high level of visible and nonvisible smoke sensitivity.

2 TECHNICAL SPECIFICATIONS

Operating voltage	12 V ÷ 28 V
Maximum monitoring mode current	≤ 60 μA
Alarm current	20 mA
Detector sensitivity	0.2 dB/m
Maximum mounting height *)	11 m *)
Maximum supervised area *)	60 ÷ 80 m ² *)
Operating temperature range	from - 25 °C to + 55 °C
Relative humidity	up to 95 % at 40 °C
Dimensions (without base)	∅ 115 x 43 mm
Mass (without base)	0.15 kg
Casing colour	black
Casing ingress protection	IP 42
Intrinsic safety rating	Ex i _b IIC T6

*) *design guidelines must be observed*

3 INSINTRIC SAFETY PARAMETERS

Supply line marginal parameters:

Maximum input voltage	U_i	25 V
Maximum input current	I_i	99 mA
Maximum input power	P_i	0.613 W
Maximum inner capacity	C_i	0*
Maximum inner inductance	L_i	0*
Maximum outer capacity	C_o	110 nF **
Maximum outer inductance	L_o	2.5 mH**

Detector-alarm indicator connecting line parameters:

Maximum output voltage	U_o	25 V***
------------------------	-------	---------

Maximum output current	I_o	99 mA***
Maximum output power	P_o	0.613 W***

* negligible parameters

** represents the sum of capacity and inductance resulting from the length of cables that may be connected to the detector

*** values that may occur in case of uncountable damages.

Intrinsically safe barrier or separator parameters:

Maximum output voltage	U_o	25 V
Maximum output current	I_o	99 mA
Maximum output power	P_o	0.913 W
Maximum outer capacity	C_o	110 nF
Maximum inner inductance	L_o	2.5 mH

Connecting cable example (YnTKSY):

Core diameter	mm	0.8	1.0
Single core resistance	Ω /km	37.5	24
Pair of cores capacity	nF/Km	120	120
Inductance	mH/km	0.7	0.7

4 SAFETY CONDITIONS

4.1 Repairs and maintenance

Any maintenance works or periodic inspection shall be executed by skilled personnel employed by companies authorised and trained by POLON-ALFA.

Any repairs must be carried out by the manufacturer. POLON-ALFA bears no responsibility for the operation of any apparatus being repaired by unauthorised personnel.

4.2 Works at height

Any detector installation works carried out at height must be executed with particular care utilising tools and machinery in good working condition.

Special attention shall be given to stability of ladders, elevators, lifts, etc.

Any electric tool shall be used strictly obeying the safety rules stated in instruction manuals by manufacturers.

4.3 Anti-dusting eye protection

It is obligatory to use protective anti-dusting glasses and masks during detector installation works that produce high amount of dust, such as hole drilling in ceilings.

5 INTEROPERATION WITH CONTROL PANELS

The DUR-40Ex detectors are provided for working together in fire detecting lines with control panels manufactured by POLON-ALFA or by other producers that obtained POLON-ALFA's consent and compatibility declaration.

The DUR-40Ex detectors should be applied in explosion hazard zones being connected to detecting lines behind an intrinsically safe barrier or separator indicated in the control panel technical documentation.

6 CONSTRUCTION DESCRIPTIONS

The detector's mechanical construction is shown on Figure 1. Its basic element is a detecting optical module consisting of transmitting and receiving diodes. They are fixed in a holder in such a way that radiation emitted by the transmitting diode does not reach the receiving diode directly. The detecting module (holder with diodes) is mounted on a printed board that comprise also a circuit with the detector's monitoring processor. The optical module is protected by a labyrinth, damping external radiation. A wire mesh net prevents irruption of small insects or bigger pieces of dirt. The whole structure is placed in a black plastic housing consisting of basket, screen and detector casing.

The DUR-40Ex detector is installed in the G-40 base where also detecting line cables are connected to.

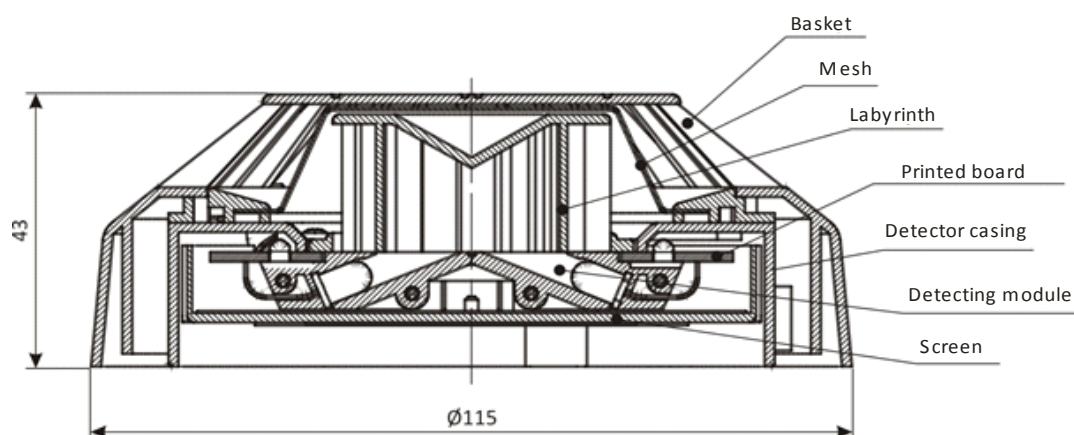

Fig.1 DUR-40Ex mechanical structure

7 PRINCIPLES OF OPERATION

The DUR-40Ex is a Tyndall effect optical smoke detector – light scattering on smoke particles. Its basic element is a detecting optical module consisting of an electroluminescence diode that transmits radiation and an optical receiving diode. The optical module and surrounding measuring chamber are protected by a labyrinth which is shaped to dump both external light and radiation resulting from internal reflexes of the transmitting diode light. When smoke particles enter the measuring chamber, they reflect the light emitted by the transmitting diode. The reflected light reaches the optical diode producing photocurrent which is first strengthened and processed and then analysed by the microprocessor installed inside.

An alarm mode is indicated with red light emitted by a signalling diode installed on the detector casing. The indicator enables fast localisation of the activated detector and is helpful in periodic detector's inspections. In case the detector is installed in a hard to reach space, an additional optical alarm signal can be obtained by connecting the WZ-31 alarm in an accessible and visible place.

The DUR-40Ex detector has a built-in self-regulation digital system maintaining constant sensitivity to progressing dirt build-up inside the measuring chamber. After exceeding the pre-set regulation threshold the detector sends an alarm signal to the control panel.

8 MAINTENANCE INSTRUCTIONS

The DUR-40Ex optical smoke detector should undergo periodic inspections, carried out at least once in 6 months, to prove that the detector operates correctly and works together with the fire control panel properly. Those checks are executed using smoke imitating aerosol.

The detector's long-term utilisation may result in dirt built-up inside its measuring chamber.

After exceeding the set self-regulation threshold resulting from progressing dirt build-up in optic chamber, the detector may enter an alarm mode. It is why prior cleaning of detector's optical module (labyrinth and lenses of both transmitting diode and receiving photodiode) is vital.

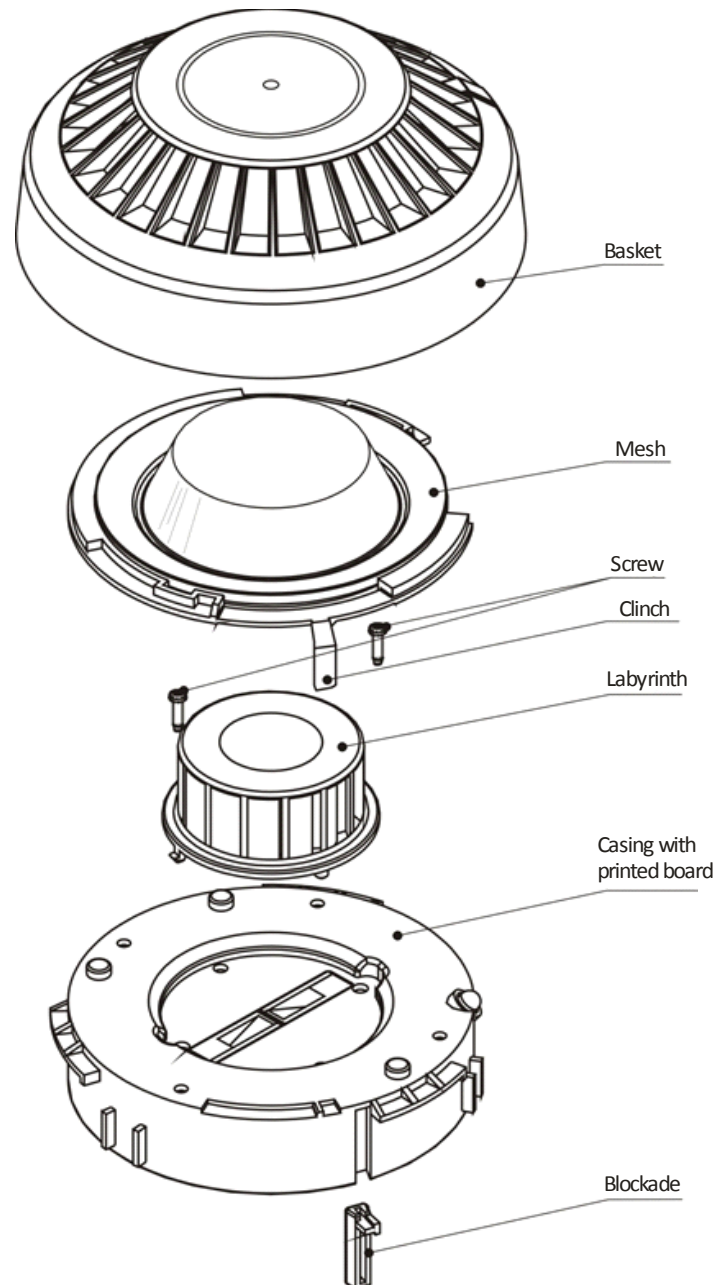

Fig. 2 Detector elements

The detector assembly and dismantling process is shown on Figure 2. In order to dismantle a detector the following operations should be carried out:

- pressing the long mesh clinch turn the casing right against the basket until it is released
- remove the screen
- unscrew two labyrinth fixing screws and remove the labyrinth
- carry out necessary cleaning.

It is recommended to clean the detector using a delicate brush and vacuum-cleaner; it is also allowable to use compressed air. The labyrinth may be washed with warm water mixed with wash-up liquid. No water stain should be left on the labyrinth surface after washing and drying.

After cleaning the detector should be assembled, tested using a smoke imitator and installed again in the detecting line. In order to assemble the detector:

- a) fix the labyrinth with two screws
- b) install the screen
- c) place the basket in the opposite direction as it is shown on the drawing
- d) insert the shield into the basket so that the diode is placed slightly to the right against the glass
- e) turn the detector casing maximally to the left.

Note:

In case the cleaning does not produce the required result, it is necessary to send the detector to the manufacturer for repair.

9 DETECTOR INSTALLATION

The DUR-40Ex detectors shall be installed (location, height, etc.) in accordance with general design rules. They are mounted in places where the equipment working or materials stored may emit smoke resulting from their burning or smouldering. The detectors are installed in 40 model range bases.

The detection line installation instructions are shown on Figure 3 and in the G-40 Installation and Maintenance Manual. It is possible to connect the WZ-31 alarm indicator that provides additional visual alarm of a particular detector or a group of detectors.

Alarm installation cables should be placed in accordance with low-voltage (below 42V) circuit regulations.

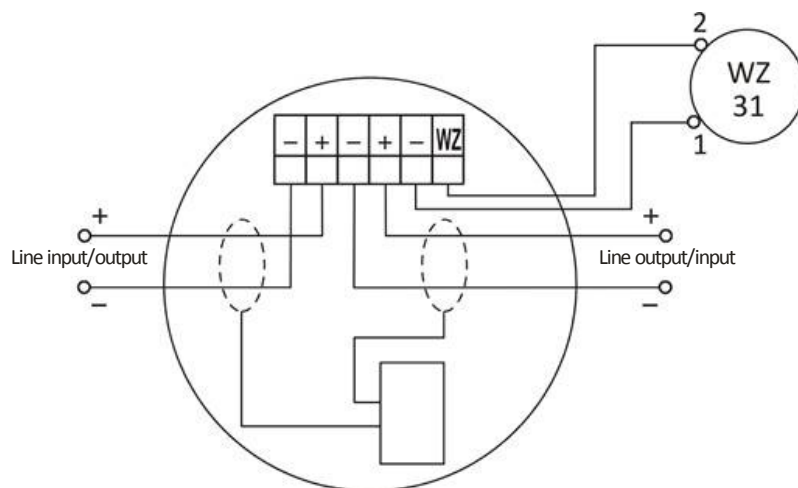

Fig. 3. Clamps of a base interoperating with detector plug

Note:

The detectors cannot be installed in corrosive atmosphere containing caustic gases and vapours or dust pollution. Steam condensation on the detector surface is strictly forbidden.

10 STORAGE AND TRANSPORTATION

10.1 Storage

The DUR-40Ex detectors must be kept in closed rooms free of any caustic gases and vapours at ambient temperature between 0 °C and +40 °C and relative humidity not exceeding 80% at + 35 °C. The detectors shall not be exposed to direct sunlight or high temperature emitted by heaters.

The storage period of the detector in transport package should not exceed 6 months.

10.2 Transportation

The DUR-40Ex detectors should be carried in closed spaces of transport means in proper packages that meet appropriate transport regulations. Transport temperature shall not be lower than - 40 °C and higher than + 70 °C; relative humidity shall not exceed 95% at + 45 °C or 80 % at + 70 °C.