

## Extension Module Type FD 4201 Instruction Manual 05/12.17

### General Description

Module FD 4201 is optional for the fire control panel FS4000. Expands the functionality of the fire control panel, as follow:

- Connection of fire control panel FS4000 in a system of a repeater FS5200R and/or several remote fire control panels FS4000, FS5100, FS5200, FS5200E;
- Trigger dry contact fire output for each zone that is in Fire condition.

The module could work only with the latest version of the fire control panel FS4000 (fire control panels with serial numbers higher than 4000). Module FD4201 is manufactured in 4 versions (2,4,6 or 8 dry-contacts), related to the 4 types of the FS4000 panel (2,4,6 or 8 fire zones).

The RS485 interface is built-in the module in each of its 4 types.

The module includes:

- Interface RS485 for connection with repeater FS5200R;
- Potential free dry-contacts for Fire condition (one to each zone of the fire control panel FS4000).
- The unit consists of a printed circuit board and ribbon cable.

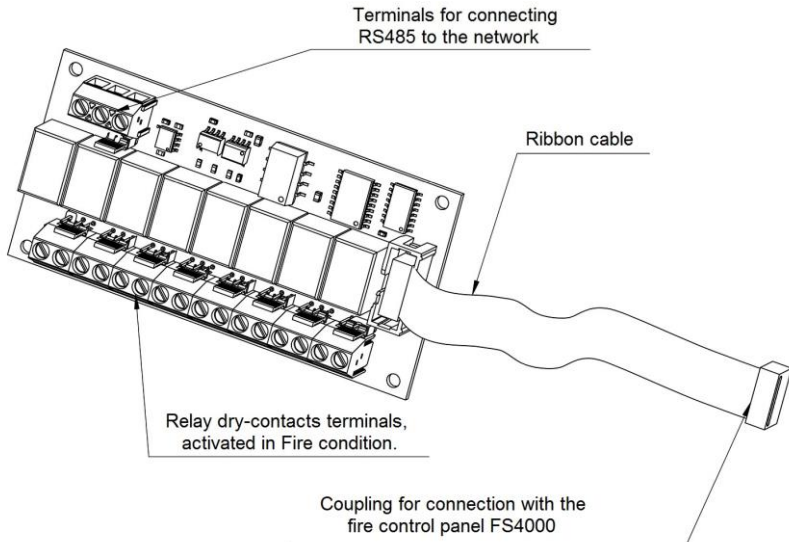

Fig.1

The power supply and communication interface are on the same ribbon cable connecting the FS4000 fire control panel and the FD4201 extension module.

## Technical Data

Relay outputs for Fire condition

- type potential free, switching
- power supply 3A/125VAC; 3A/30VDC

Interface RS485

- network address not-programmable, the 4 digits of the serial number of the FS4000 panel
- data exchange speed fixed – 9600 bits/s.

Operational temperature range from minus 5°C to 40°C

Relative humidity resistance max 93% at 40°C

Dimensions 100 x 50 x 15 mm

Weight 0,60 kg

## Installation

The installation sequence is as follow:

### 1. Preliminary steps:

1.1. Unpack the module.

1.2. Configure the jumpers of the dry-contacts (normal open or normal close) depending on the specific project requirements, pos. 3 (fig. 2).

1.3. Terminate the interface RS485 network line (refer the Instruction Manual of Fire Control Panel FS4000):

- if the connected fire control panel is the first or the last one in the network line, switch on the jumper in the module, pos. 1 (fig. 2).

- if the fire control panel is in the middle of the network line, then– the jumper is switched off.

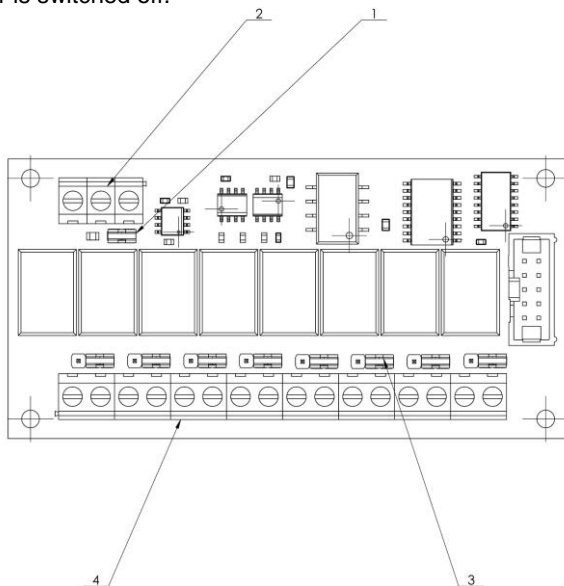

Fig.2

## 2. Installation of Extension Module FD 4201 in fire control panel FS4000

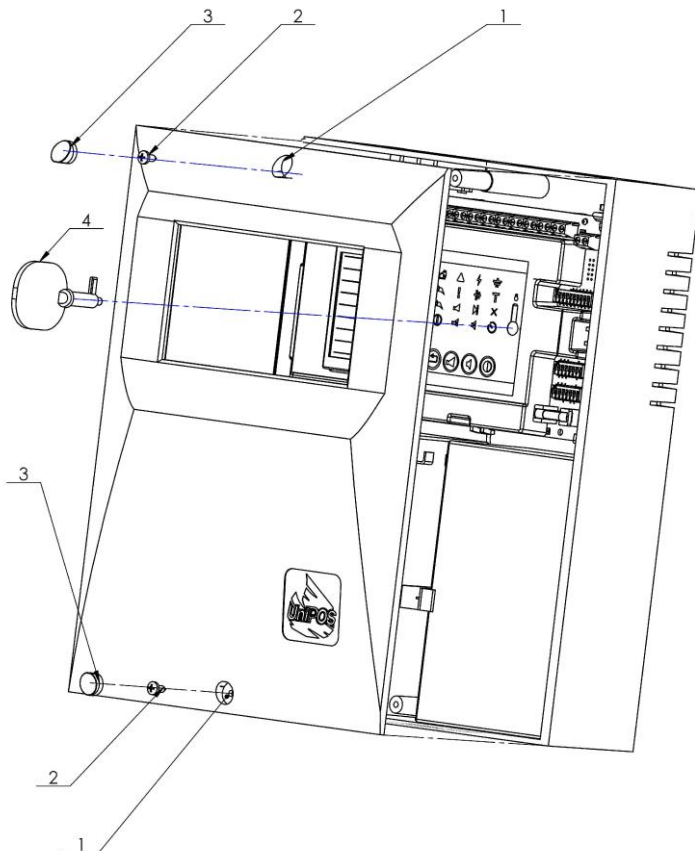

Fig.3

- 2.1.** Open the front cover of the fire control panel.
- remove the access level key (fig.3, pos.4);
  - remove the plastic plugs (fig.3, pos.3);
  - remove the screws of the dedicated openings on the front cover (fig.3, pos.1 and pos.2);

- 2.2. Switch off the mains power line in FCP.
- 2.3. Switch off the back-up batteries in FCP.

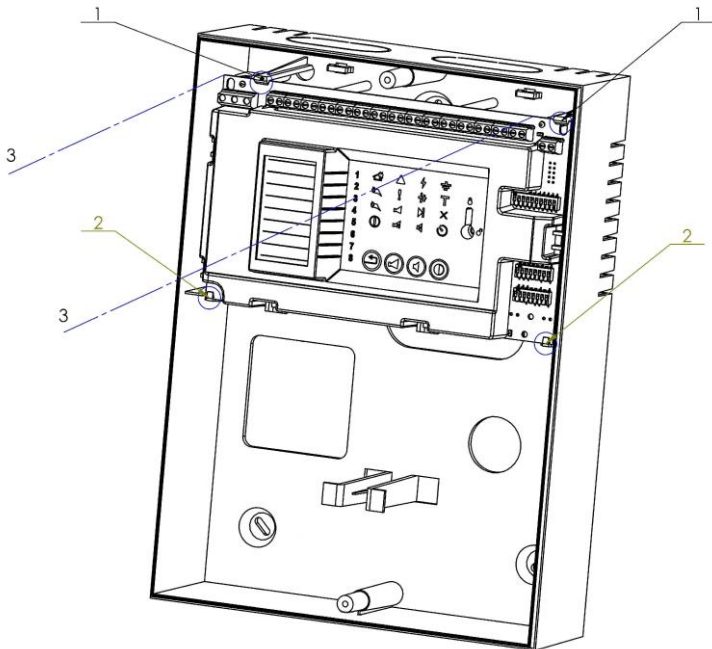

Fig.4

- 2.4. Pull-out the main interface board (fig.4) following the sequence:
  - push the holders on the top side (fig.4, pos.1);
  - take out (from the top holders) the interface board and leave it fixed on the bottom holders (fig.4, pos. 2);
  - pull the interface board out of the bottom side holders (fig.4, pos. 3), till fully released;

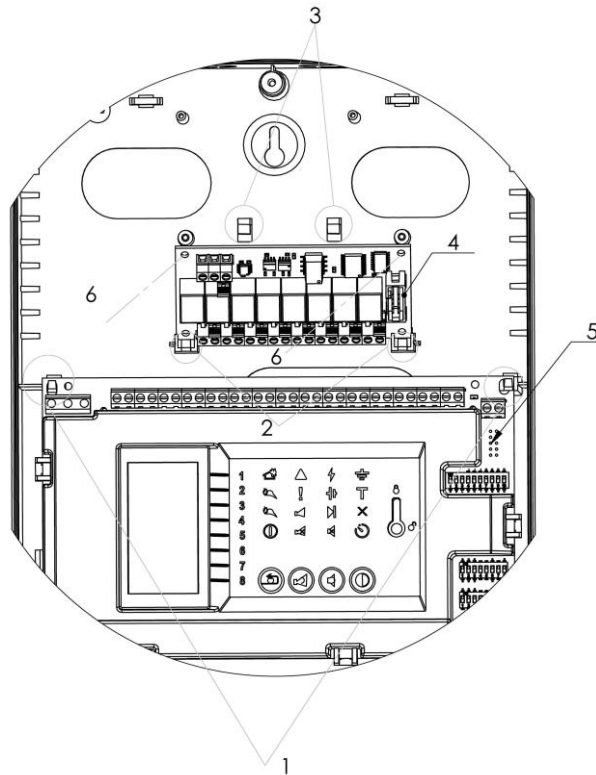

Fig.5

**2.5.** The main interface board in FCP is mounted to the bottom holders, as illustrated on fig.5, pos.1.

**2.6.** The bottom side of the extension module is mounted on the holders (fig.5, pos.2);

The top side of the extension module is pushed (fig.5 pos.6) until the top-side holders click to fix it (fig.5, pos.3);

**2.7.** Connect the ribbon cable to the module, fig.5 pos.4 and to the connector located on the FS4000 main PCB, fig.5 pos.5. The connectors are provided with a slot, determining the direction of the connection. network line

### 3. Connecting the interface and the commutated output devices

3.1. Take out the network line and the line of end output devices through the dedicated openings (refer the Instruction Manual of Fire Control Panel FS4000).

3.2. The network line is connected to module 4201, on the terminals "A" and "B", pos. 2 (fig. 2).

3.3. Connect the end output devices lines in dry-contacts terminals of module 4201, pos. 4 (fig. 2).

### 4. Start-up procedure of the FS4000 panel with FD4201 installed

4.1. Switch on the mains power line in FCP.

4.2. Switch on the back-up batteries in FCP.

4.3. Close the front cover of the fire control panel.

**The entered delay for the FS4000 monitored outputs is the same like the delay of the FD4201 dry contacts.**

### Testing

Extension Module FD 4201 is tested after installation as an element of the fire control panel or during maintenance activities.

#### 1. Testing of the dry-contacts part.

- Set time-delay of the outputs "0" minutes in the fire control panel by means of jumper J1 (refer the Instruction Manual of Fire Control Panel FS4000);
- Simulate fire condition in a randomly selected zone (for example: line/zone 1);
- The fire control panel enters Fire condition and the dry-contact, corresponding to the selected zone, is activated (example: Rel1 – for line 1);
- If the dry-contact is configured like normally open contact, then in Fire condition it is closed;
- Press button  to reset the fire control panel. The dry-contact (e.g.: Rel1) must be reset to its initial position;
- If no other dry-contact of another line is going to be tested, reset the delay of the fire control panel to its initial settings (0, 1, 2, 3, 4 or 5 minutes).

**ATTENTION! The dry-contacts of the FD4201 extension module must not trigger 220 Vac (the maximum rating is 125 Vac or 30 Vdc) !**

## **2. Testing the interface part.**

The interface part RS485 of the Extension Module FD 4201 is tested as a part of a local network of repeater FS5200R and remote fire control panels. The parameters of the repeater have to be set-up accordingly, in order to communicate with the FS4000 panel. The network address and the data communication speed along RS485 in a fire control panel, equipped with an extension module are fixed:

- The fire control panel network address coincides with its serial number;
- the data communication speed is fixed – 9600 bits/s.

### **Complete set**

PCB Extension Module	- 1 pc.
Ribbon cable	- 1 pc.
Instruction manual	- 1 pc.
Package	- 1 pc.

### **Technical service**

It should be done only by an authorized person as it during the actions for the technical maintenance of the fire control panel.

### **Warranty**

The warranty period is 24 months from the date of sale.

The manufacturer guarantees the normal performance of the unit providing that the operation requirements set herewith have been observed.

The manufacturer does not bear warranty liabilities for damages caused through accidental mechanical damage, misuse, adaptation or modification after production.

The manufacturer bears warranty liabilities for damages in the unit caused through manufacturer's fault only.

Manufacturer  
UniPOS LTD  
47 San Stefano Str. Pleven 5800  
<http://www.unipos-bg.com>

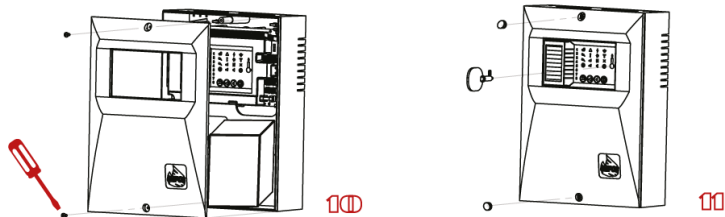
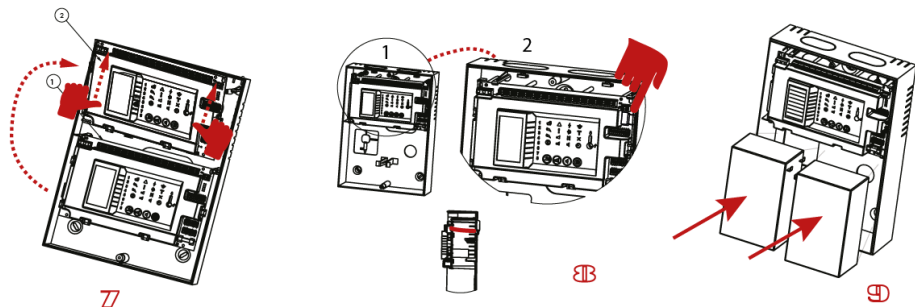
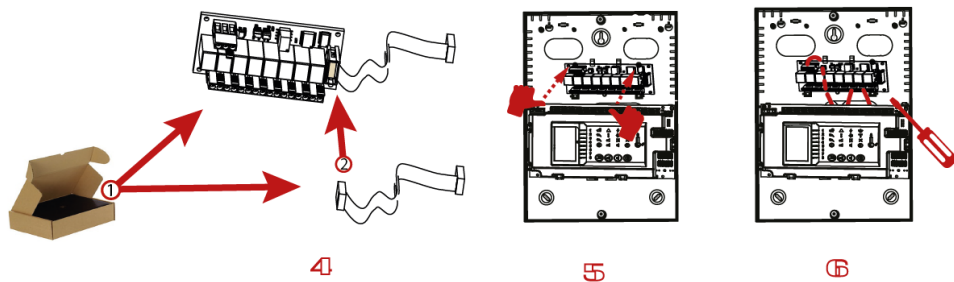
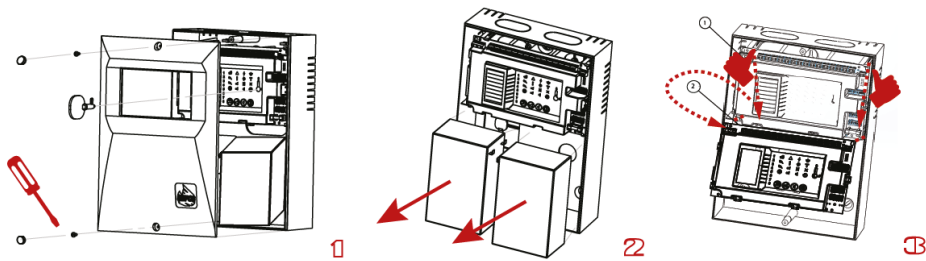

[www.unipos-bg.com](http://www.unipos-bg.com)