

INTERFACE MODULE RS232/485

Instruction Manual 03-INT-02-17

General description

Interface Module RS232/485 is designed for implementing the communication function between fire control panels and a personal computer or between fire control panels, connected into a network. The module is installed in Fire Control Panels FS5100, FS5200.

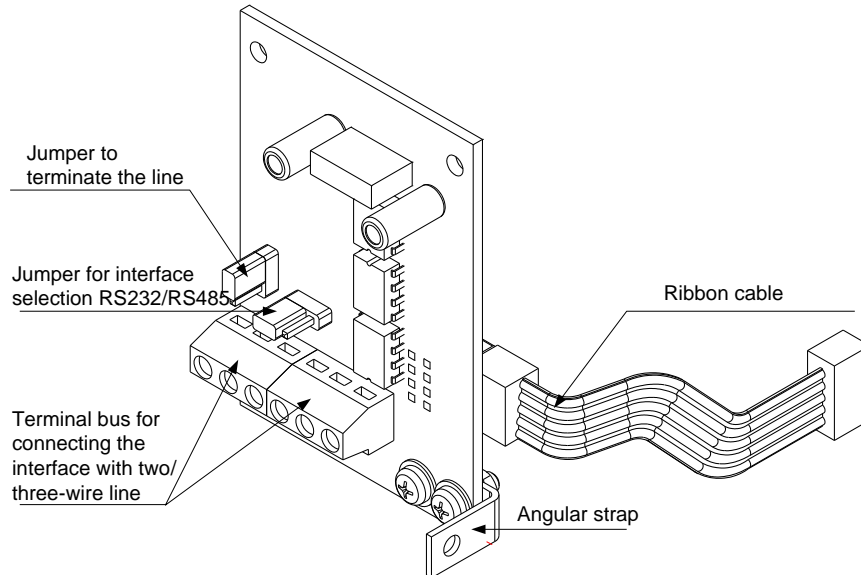

Fig.1

Technical data

Supply voltage	- (5±0.25)VDC
(the module is power supplied from the fire control panel via a ribbon cable)	
Consumption	- 10mA
Operational temperature range	- from minus 10°C to plus 60°C
Relative humidity	- (93±3)% at 40°C
Dimensions	- (67x50x44) mm

Installation

1. Interface Module RS 232/485 installation steps

1.1. Unpack the module

1.2. Select the communication interface corresponding to the desired network functionality pos.1 (Fig.2):

- for RS232 communication – the jumper is in position ;
- for RS485 communication – the jumper is in position .

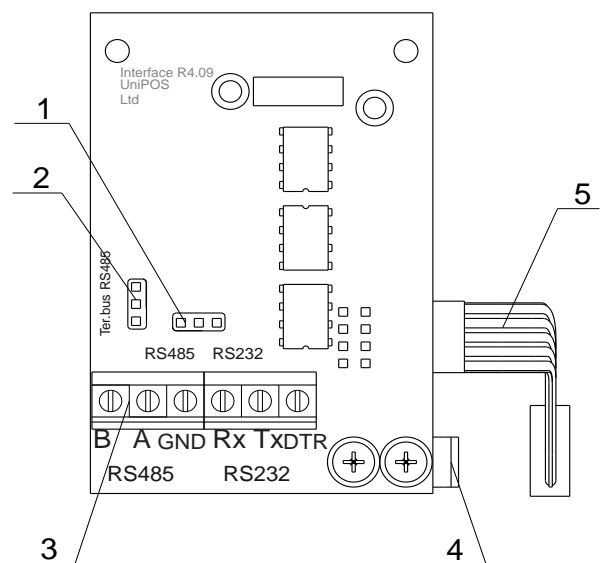

Fig.2

1.3. In case of RS485 communication, terminate the line resistance by means of the jumper pos.2 (Fig.2):

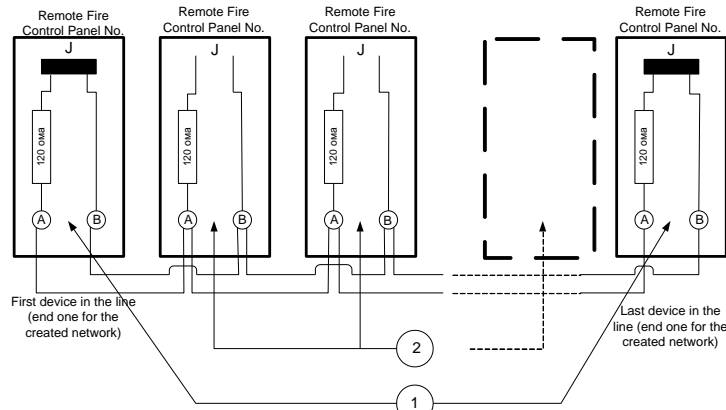



Fig.3

- If the fire control panel, connected to the local network, is an end one then set the line terminating jumper pos.1 (Fig.3) to position  (On);
- If the fire control panel, connected to the local network, is not an end one then set the jumper pos. 2 (Fig.3) to position  (Off).

2. Installation of Interface Module RS232/485 in Fire Control Panel FS5100

2.1 Install the angular strap pos.1 (Fig.4) by means of the screws pos.2 (Fig.4).

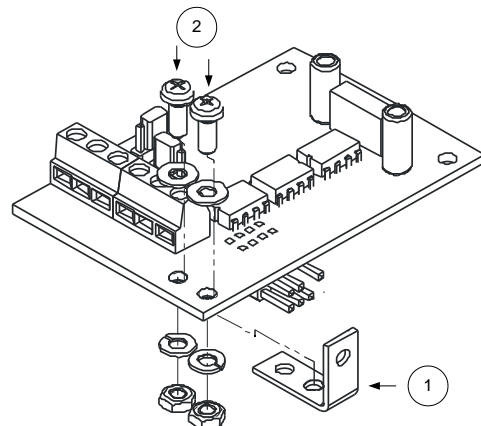

Fig.4

- 2.2. Unscrew the two screws from the cover of the fire control panel pos.1 (Fig.5).
- 2.3. Dismantle the cover
- 2.4. Remove the fuse Fu1 from the socket pos.2 (Fig.5).
- 2.5. Disconnect the cables from the terminals of the back up batteries pos.3. (Fig.5).

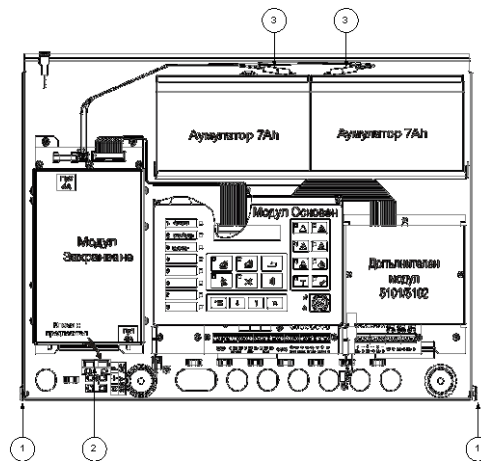

Fig.5

2.6. Install the module as shown on Fig.6 and fix it by means of the third screw from the set. The general view of the Fire Control Panel FS5100 with installed module is shown on Fig.7.

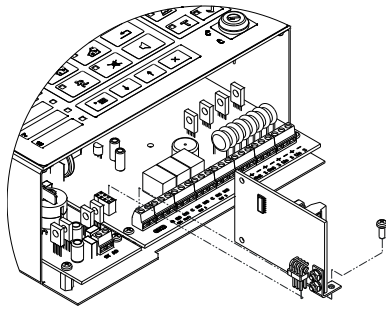

Fig.6

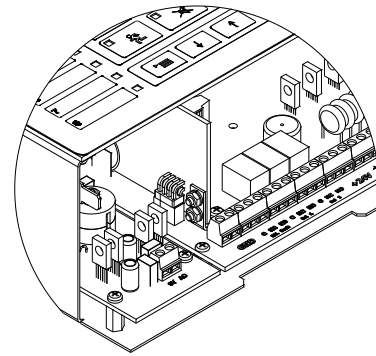

Fig.7

2.7. Connect the local network wires Fig.8:

- if the interface is type RS232, connect the three-wire line to terminals Rx, Tx and GND pos.2 (Fig.8);
- if the interface is type RS485, connect the two-wire line to terminals „A” and „B” pos.1 (Fig.8).

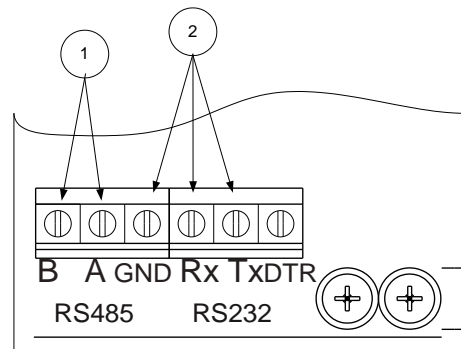

Fig.8

2.8. Put back Fuse Fu1 to the socket pos.2 (Fig.5).

2.9. Connect the cables to the terminals of the back up batteries pos.3 (Fig.5).

2.10. Mount the dismantled cover of the fire control panel.

2.11. Screw in the screws of the fire control panel cover pos.1 (Fig.5).

2.12. Go to Menu *System Functions, Setup, Fire Control Panel Parameters, Network Number* and enter a network number of the fire control panel. The option is to enter a four-digit network number (the default number is 1234).

2.13. Enter the interface speed (the default speed in the fire control panel is 9600 bits/s).

2.14. Upon exit Setup menu the fire control panel enters Duty Mode.

3. Installation of Interface Module RS 232/485 in Fire Control Panel FS5200

3.1. Unscrew the two screws from the cover of the fire control panel pos.1 (Fig.9).

3.2. Dismantle the cover

3.3. Remove the fuse Fu1 from the socket pos.2 (Fig.9).

3.4. Disconnect the cables from the terminals of the back up batteries pos.3 (Fig.9).

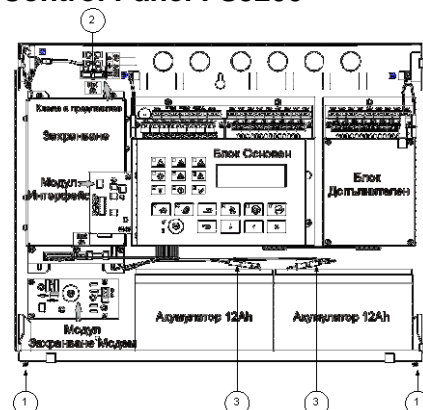

Fig.9

3.5. Connect the ribbon cable from the set to the module; observe the direction marks pos.1 (Fig.10) and pos. 2 (Fig.10)

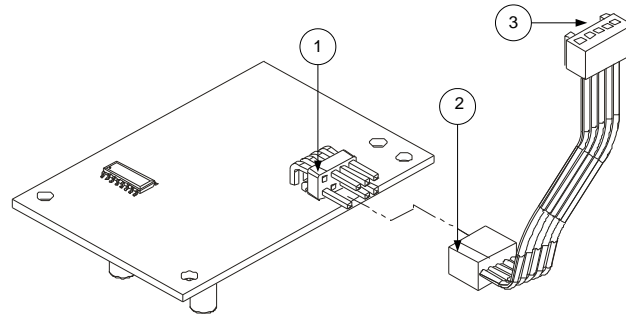

Fig.10

3.6. Install the module as shown on Fig.11 and fix it by means of the three screws to the box of the Main Module.

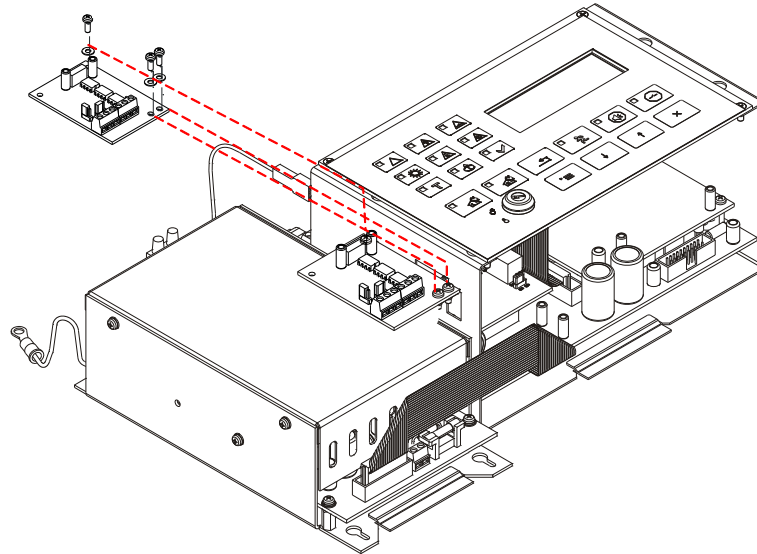

Fig.11

3.7. Pass the ribbon cable pos.3 (Fig.12) through the installation hole pos.2 (Fig.12) and connect it to the coupling pos.4 (Fig.12) of the main module; observe the direction pointed by the marks pos.3 (Fig.10).

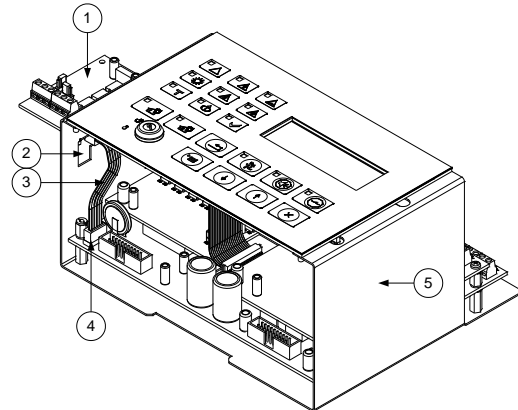

Fig.12

3.8. Connect the local network wires Fig.8:

- if the interface is type RS232, connect the three-wire line to terminals Rx, Tx and GND pos.2 (Fig.13);
- if the interface is type RS485, connect the two-wire line to terminals „A” and „B” pos.1 (Fig.13).

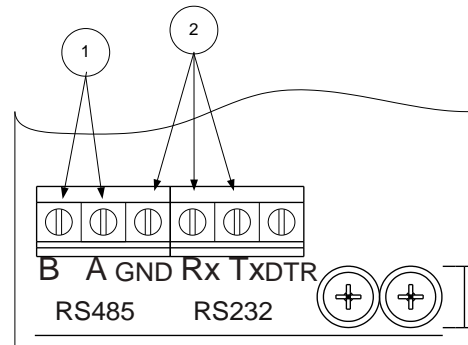

Fig.13

3.9. Put back Fuse Fu1 to the socket pos.2 (Fig.9).

- 3.10.** Connect the cables to the terminals of the back up batteries pos.3 (Fig.9).
- 3.11.** Mount the dismantled cover of the fire control panel.
- 3.12.** Screw in the screws of the fire control panel cover pos.1 (Fig.9).
- 3.13.** Go to Menu *System Functions, Setup, Fire Control Panel Parameters, Network Number* and enter a network number of the fire control panel. The option is to enter a four-digit network number (the default number is 1234).
- 3.14.** . Enter the interface speed (the default speed in the fire control panel is 9600 bits/s).
- 3.15.** Upon exit Setup menu the fire control panel enters Duty Mode.

Additional options

The Interface Module is a universal, galvanic separation device for conversion from TTL levels to the electrical parameters of RS232 and RS485 interfaces.

The communication interface is selected by means of a jumper on the PC Board.

Figure 14 shows the layout of the PC Board coupling signals when it is connected to the fire control panel or to the devices with TTL.

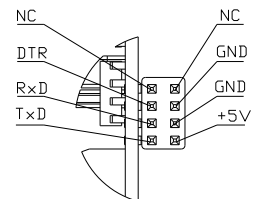

Fig.14

Complete set

PC Board	- 1 pc.
Ribbon cable	- 1 pc.
Angular strap	- 1 pc.
Screw 3x6	- 3 pcs.
Nut M3	- 3 pcs.
Washer Ø3	- 3 pcs.
Instruction manual	- 1 pc.

Warranty

The warranty period is 24 months from the date of sale providing that the installation requirements have been observed.

The manufacturer does not bear warranty liabilities for damages caused through accidental mechanical damage, misuse, adaptation or modification after production.

UniPOS

47, "San Stefano" Str., 5800 Pleven, BULGARIA
 phone +359 64 891111, +359 64 891 100, fax +359 64 891 110
 e-mail: office_pleven@unipos-bg.com

Mladost 1, bl.79B, entr.2, ap.17, 1784 Sofia, BULGARIA
 phone/fax +359 2 9744469, +359 2 9743925
 e-mail: office_sofia@unipos-bg.com

www.unipos-bg.com